

Chiller Installation Instruction

WOODBIDGE®

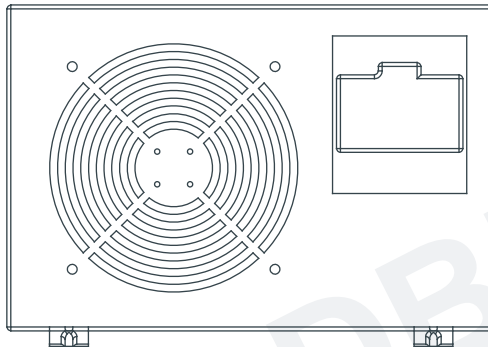

BCH1000
WCH2000



READ ALL INSTRUCTIONS BEFORE UNPACKING THE PRODUCT

INSTRUCTIONS THAT, IF IGNORED, COULD RESULT IN DEATH OR SERIOUS INJURY CAUSED BY INCORRECT HANDLING OR INSTALLATION OF THE PRODUCT. THESE INSTRUCTIONS MUST BE OBSERVED FOR SAFE INSTALLATION.

CAUTION!



**TWO PEOPLE
LIFT REQUIRED**

**2 PEOPLE ARE REQUIRED TO LIFT AND DURING
ENTIRE INSTALLATION OF THIS PRODUCT**

This product must be installed by a fully insured and licensed HVAC installer.

The chiller uses R410A refrigerant. WOODBRIDGE does not offer nor is responsible for refilling the refrigerant. Please hire a fully insured and licensed HVAC installer for maintenance, refrigerant refill, troubleshooting, and repair of the chiller.

We are not responsible for local codes compliance for this product. Building and plumbing codes may vary from state-to-state in accordance to your location. We are not responsible for providing any compliance certifications. Under no circumstances we shall not be liable for any incidental damage sustained in connection with this product. Neither manufacturer, nor distributor, nor retailer is responsible for water damage or flood caused by the usage of this product. Under no circumstances we shall not be liable for any and all fees, cost of installation/reinstallation/removal, subsequent damage or transportation costs in case of the product defect.

The connection instructions in this manual are for general reference. The actual connections may vary by the type of cold plunge tubs you purchase.

Accessories:



•Quick connector*4



•Chiller Water Drainage Tube*1



•GFCI Plug



•Wheel*4



•Chiller Filter Container(built-in)*1



•Chiller Filter Cartridge*2



•Filter Container Wrench*1

1. Working principle

The chiller cools down the water with the compressor inside. Then, the water circulates back to the wooden tub to lower the temperature of the tub water. In certain models, the chiller can also warm up the water with its built-in heater.

Water Circulation: Wooden Tub -> Water Filter -> Chiller -> Wooden Tub -> Water Filter -> Chiller -> Wooden Tub -> Repeat

Note: Depending on the size of the tub and the environmental temperature, the tub water may take more than 15 minutes to increase or decrease 1 degree.

Principle diagram

Power plug

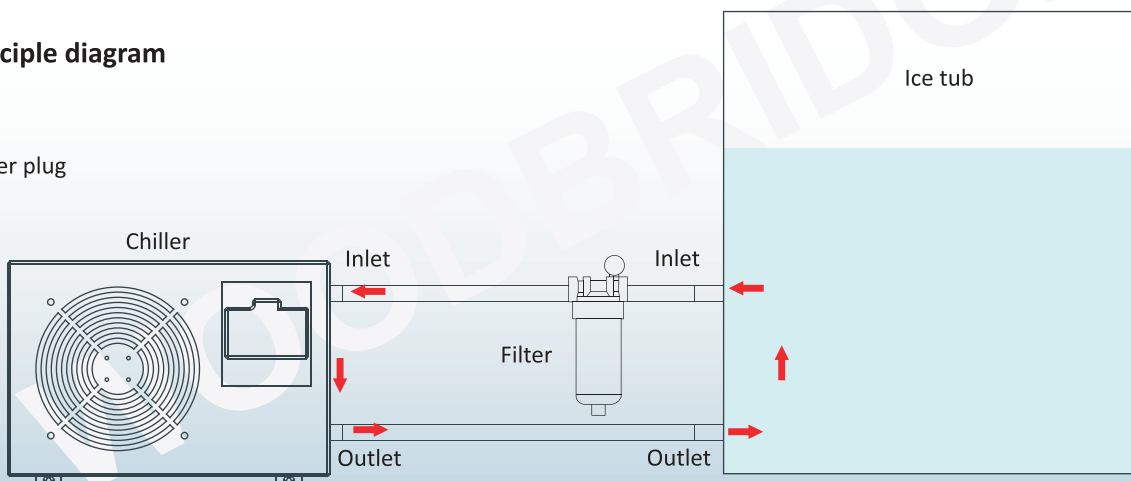

2. Installation Instruction

Chiller installation

- ① Install the chiller in a stable place to avoid the impact of water level backflow. The ice tub's inlet hole should be set to a higher level than the inlet of the chiller.
- ② Install the chiller in a clean place. Avoid too much debris gets into the tub to block the chiller system.
- ③ Install the chiller in a well-ventilated place to facilitate the exhaust of the chiller.



Hoses, chiller housing/pipelines, and tub exterior may have condensation. This is a natural phenomenon, caused by temperature difference.



1. Air inlet needs to be at least 23 5/8" away from solid obstacles, such as walls. Air outlet needs to be at least 59" away from solid obstacles (farther away the distance, less the noise is).
2. The distances mentioned above need to be strictly followed. The chiller cannot be too close to solid obstacles, such as walls. The operation of the chiller needs the air inlets and outlets. The air enters from the inlet side and comes out from the outlet side. Only when the air flow reaches a balanced circulation can the best cooling effect be reached.

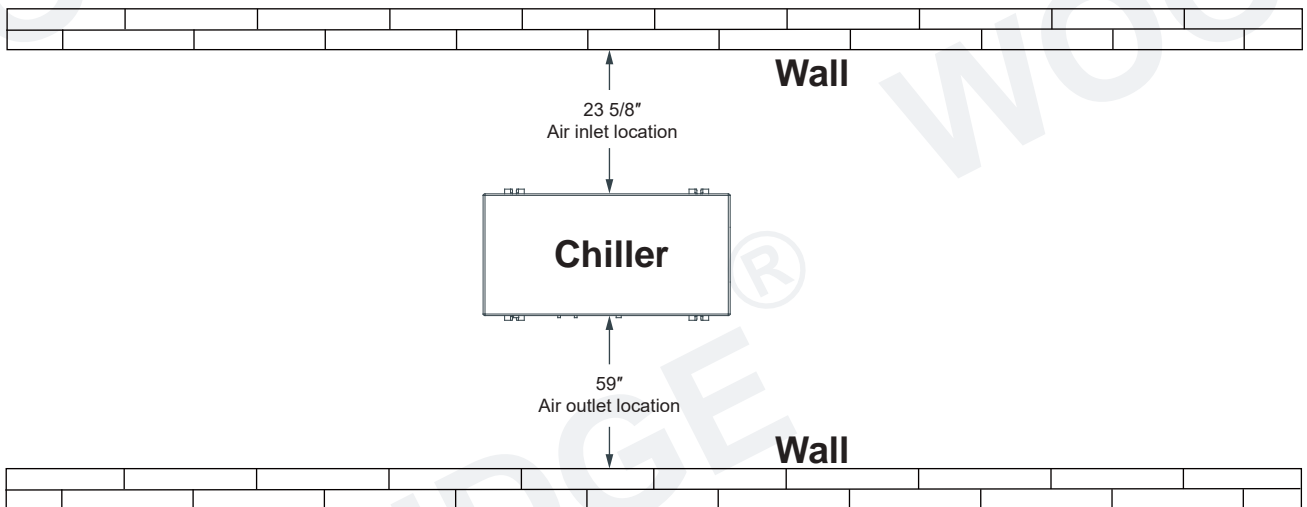

Chiller power distribution

- ① Please take safety precautions before powering any connections.
- ② Connection or replacement of wiring should comply with electrical specifications and should be performed by professionals.
- ③ Make sure the chiller voltage is consistent with the local supply voltage. The chiller is 110-120V.



3. Cold Plunge Usage

- ① Hoses connection
Connect the hoses as shown in the picture.

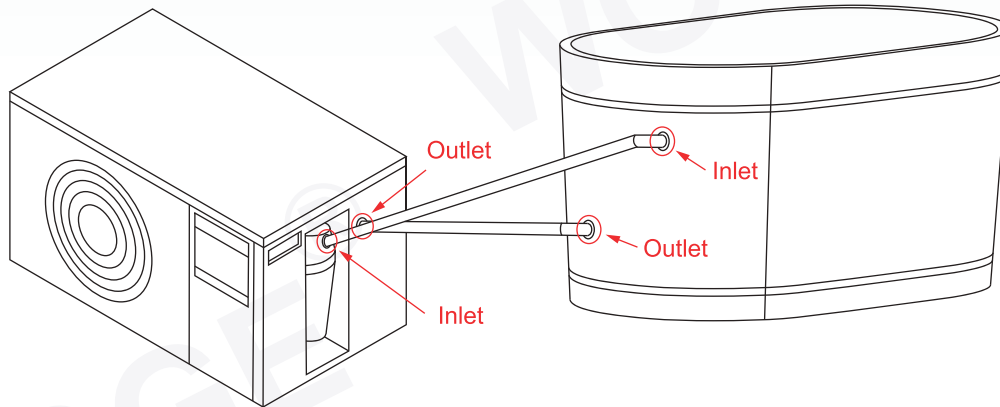

1. The cold plunge should be installed on a stable platform to avoid the influence of back flow of water level.
2. If the hoses are too narrow, they will affect the water flow and cause the chiller system to malfunction or underperform.
3. You need to find a suitable place for draining to avoid poor drainage of the cold plunge.
4. Please fill up the tub to above the minimum water level before use (higher than the water inlet and outlet inside the tub).

- ② Check and make sure the tub inlet is unobstructed (filter screen built-in) every time before usage.
The water inlet should be kept unobstructed, and the tub is kept clean. (there should be no garbage)



Clean the tub filter screen (built-in) before use, It can help prevent small debris from going into the chiller.
Regularly cleaning the tub filter screen can prolong the operational life of the chiller.

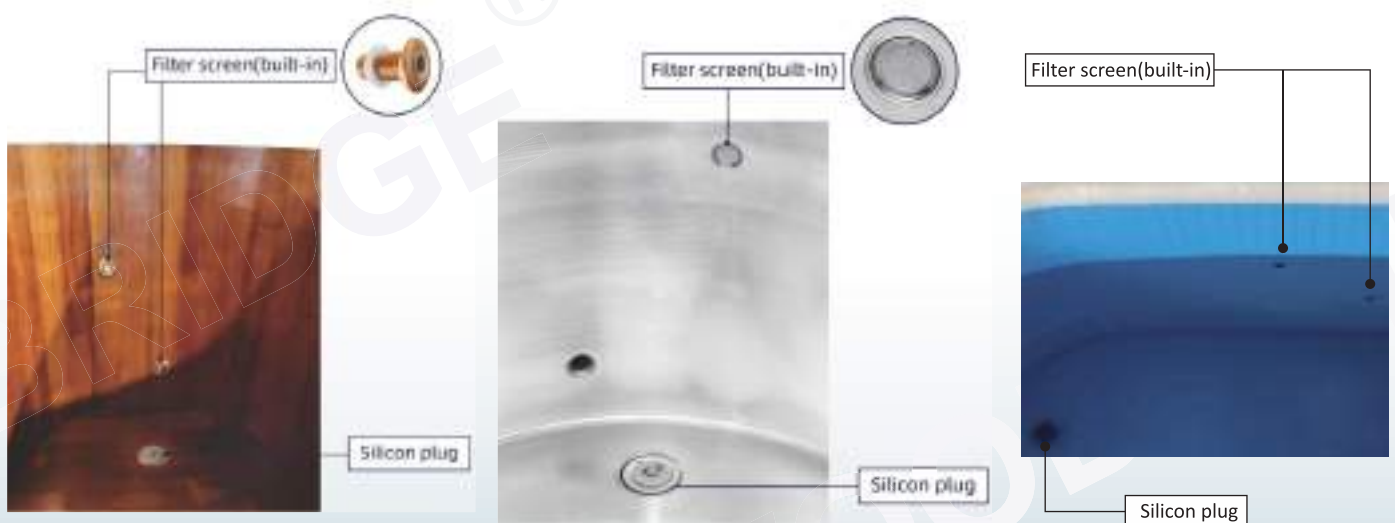

*These photos are for illustrative purposes and may not accurately represent the actual content due to the use of different materials and connectors.

③ Water filling

Start to fill water into the cold plunge with a water hose; Continue to inject water so that the water level is higher than the tub inlet and outlet.

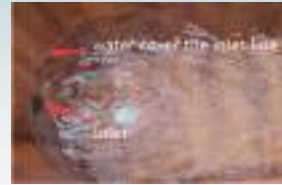

④ Use a water hose to inject water DIRECTLY into the tub water inlet. Bubbles will be flushed out from the tub water outlet. This procedure will remove any air stuck in the chiller system.



⑤ Keep injecting water DIRECTLY into the tub water inlet until no more bubbles are coming out from the water outlet. This may take 2-3 minutes. When done, please remove the hose.



***Due to the varied materials used, these photos are for illustrative purposes and may not accurately represent the actual content.**

IMPORTANT: If the air is not flushed out of the chiller completely, the cooling/heating function of the chiller will be drastically reduced.



Warning: Please make sure the chiller is always running with water. Do not run the chiller without water. The chiller can only be turned on after the water level is higher than the minimum water level line (higher than the tub water inlet and outlet)

⑥ Chiller operation

Useful tips:

1. Make sure the air inlet (fan side) and outlet are not blocked.
2. Need to fill up the water higher than the minimum water line (higher than the tub water inlet and outlet).
3. Clean the tub filter net before every use.
4. Do not remove the tub insulation cover when the chiller compressor is working. Keep the tub cover on until the tub water reaches the target temperature.
5. The tub insulation cover makes the cooling more efficient and faster. If you try to cool down the tub without the cover, you will waste more energy and may overload the chiller, causing machine errors. (The errors are temporary to protect the chiller from damage.)
6. The ozone generator's working life is ten thousand hours. After reaching its limit, please replace it with a new ozone generator.

1) Press the Key "ON/OFF" to turn on the chiller, and then click the Temperature setting. (Set the temperature with a keyboard). Cooling lamp will lighting after chilling cooling water.

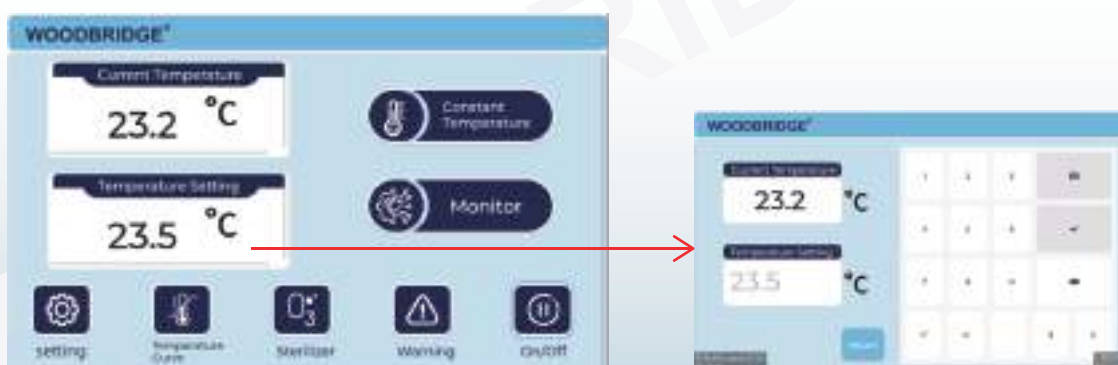

KEY DESCRIPTION

ICON	Working Logic	Display interface And how to do
	<p>When the setup temperature is lower than the current temperature, the system will cool automatically, icon "cooling" will be green.</p>	
	<p>When the setup temperature is higher than the current temperature, the system will heat automatically, Icon "heating" will be green.</p>	
	<p>Sterilizer</p>	<p>When ozone generators are running, the icon color will change to green:</p> 
	<p>Power on/off</p>	<p>When the chiller is on, the icon will change to green:</p> 
	<p>Constant Temperature situation</p>	<p>1. When the Constant temperature feature turns green it means the temperature has reached the heat you want, and the water pump will still be running. The compressor Chiller will work again once there is a 2-degree temperature difference. If you want to change to a higher temperature, you can change the setting to F1.</p> 

After heating one hour, the fan and compressor stop, pump keeps working, after 3 minutes, Ice bath chiller start to defrost which lasting 3 minutes, after defrost, the chiller restart automatically in 3 mins to continue working, the whole process lasts 9 minutes, this work logic can protect condenser that do not freeze, ensure heating function.



Defrost working logic



Temperature monitoring recorded

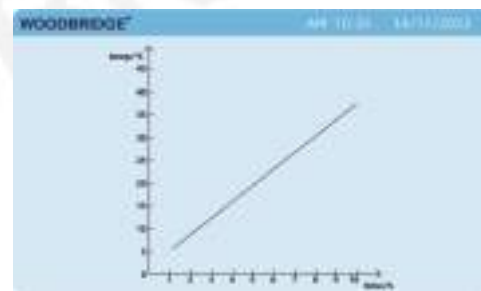

1. Click and enter the following interface: Clicking "return" then back to major screen.
2. After clicking relative Error code, enter the next interface.



Automatically self-check system (when chiller are abnormal, there will be warning).





Parameter annotation
Setting

1. Press the "Setting", then type "8888" and take "v" enter the next interface.



2. Confirm the code value you want to modify, then Click "Value", keyboard screen will pop up, input the value you need then click "v", and then pop up click "confirmed setting". Then Clicking "return" after finish setting. If nothing need to modify, just click "return" to go back. Clicking "ok" to go back major screen.



2) Press the Ozone generator button after every use. While running the ozone color icon will change to green, then you will see tiny bubbles come out from the outlet hole and will have a grassy smell. (Image 7) The ozone generator will turn off automatically in 2 hours. 2) Press the Ozone generator button after every use. While running the ozone color icon will change to green, then you will see tiny bubbles come out from the outlet hole and will have a grassy smell. The ozone generator will turn off automatically in 2 hours.





Don't run the Ozone system when people are in the chiller during cooling or heating because too high zone concentration may affect respiratory tract.
The ozone life span is ten thousand hours after it reaches those hours, you need to change to a new ozone generator.

The filter mainly filters hair, dandruff, etc. from entering the chiller system to ensure the normal operation of the chiller. If you want to achieve the purpose of purifying water, you can add flocculant and Water purifier for clarification treatment.

4. Wiring diagram

As the wiring reference, the drawing must be adjusted according to the working volt-age, power and other aspects of the corresponding equipment, and the final actual demand Add protective devices and other components, which can also be wired c ompletely according to this drawing.

- Skills requiremen:
1. Customers must use cables with UL certification;
 2. The socket is equipped with 110V 16A;

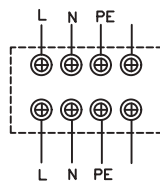

Wire diagram

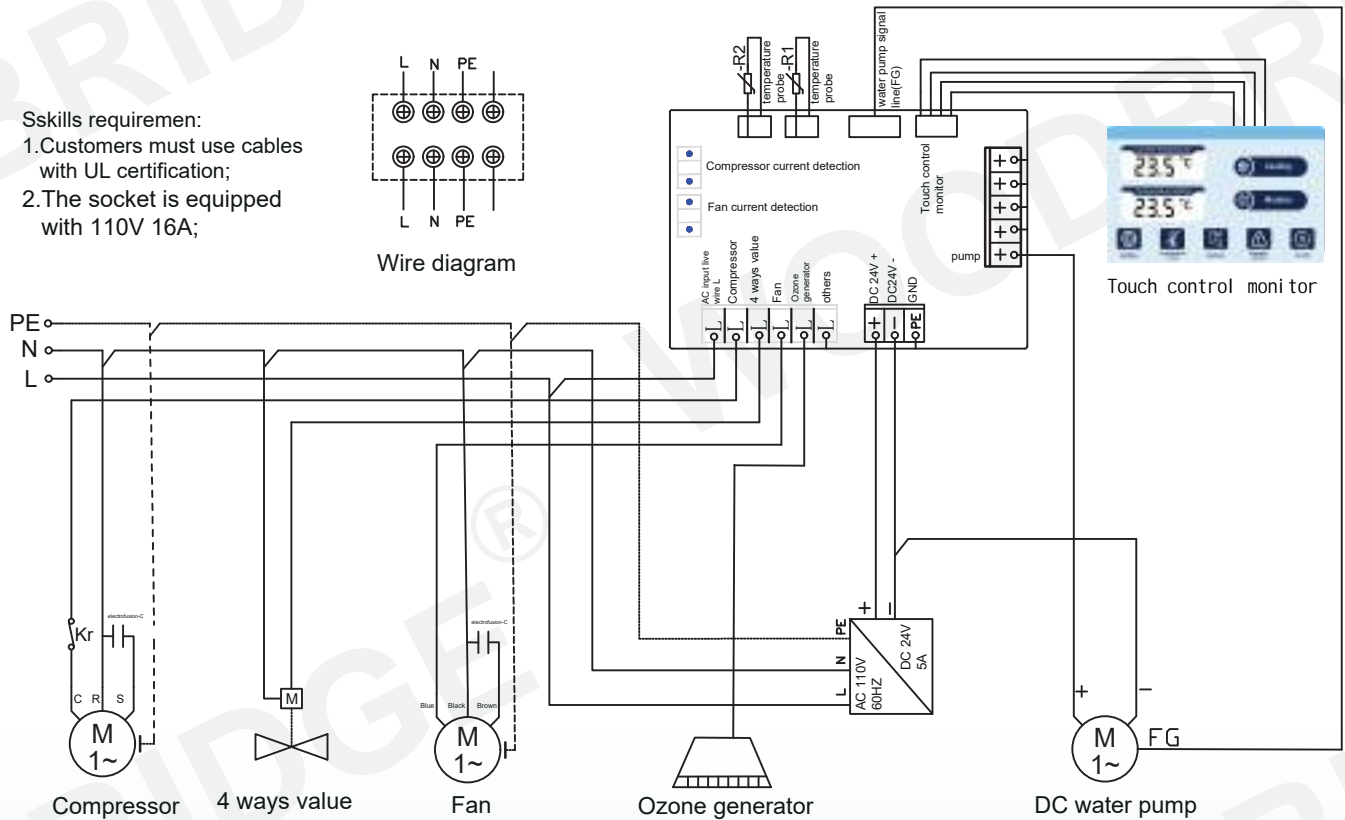

5. Circuit Wiring Diagram

Fault code

Code	Fault description	Prompt after the fault occurs	Restrict work objects
E1	Water temperature probe failure	<ol style="list-style-type: none"> 1. Check if the probe wire is damaged or disconnected 2. Check if the probe wire end is loose 	Compressor, fan, four-way valve.
E2	Water flow fault	<p>Caused by blocked water flow, it is necessary to check:</p> <ol style="list-style-type: none"> 1. Check if the water inlet of the tub is blocked (hair, paper towels, towels, leaves, etc.) 2. Check if the water outlet of the tub is blocked by foreign objects (hair, paper towels, towels, leaves, etc.) 3. If there is a mesh at the water inlet, the mesh needs to be cleaned. 4. The filter cartridge needs to be cleaned or updated. 	Water pump, compressor, fan, four-way valve
E3	Low voltage fault	The compressor pressure is too low, resulting in no short circuit between the low pressure detection port of the main board and the public	Compressor, fan, four-way valve
E4	High voltage fault	The compressor pressure is too high, resulting in no short circuit between the high-pressure detection port of the main board and the public	Compressor, fan, four-way valve
E5	Current overload	<ol style="list-style-type: none"> 1. Ensure smooth air intake from the back of the chiller (need to be at least 0.5M away from solid walls or solid obstacles) 2. The chiller can not work under the condition of ambient temperature higher 45°C 3. In the main interface, click to enter the settings menu and reset F11 to greater than the alarm value. 	Compressor, fan, four-way valve

E6	Water pump stuck fault	<p>It is usually caused by impurities (sand/hair/paper towels/leaves/insects, etc.) entering the water pump.</p> <ol style="list-style-type: none"> 1. Disassemble the water pump, remove the foreign objects, and then reassemble the water pump. 2. If water pump was damaged, please install a new pump directly. 3. Check there is must be a filter element inside of filter system. 	Compressor, fan, four-way valve, water pump
E7	No water flow fault	<ol style="list-style-type: none"> 1. Check if the water level has submerged the water inlet and outlet of the tub. If not, continue to add water to submerge the water inlet and outlet. 2. If the water level submerges the water inlet and outlet of the tub, push water pipe to pour water from the water inlet into the chiller until no large bubbles appear at the water outlet, and then start the chiller. 	Compressor, fan, four-way valve, water pump
EH	High temperature fault	Poor contact of communication interface and communication line to connector, or burning of communication chip	Compressor, fan, four-way valve
EL	Low temperature fault	The equipment has reached the set service life, please contact the engineer	Compressor, fan, four-way valve
E9	Fan current overload		Compressor, fan, four-way valve
E10	Water pump current overload		Compressor, fan, four-way valve, water pump
E11	Inlet water temperature sensor fault		System works normally
EE	Communication fault	<ol style="list-style-type: none"> 1. Check if the probe wire is damaged or disconnected 2. Check if the probe wire end is loose 	System works normally
CCC	Equipment maintenance warning		System works normally

Parameter list

code	Menu content	Range	Ex-factory	Company
F01	Temperature return difference	0.3-10	2	°C
F02	Temperature correction	-5-5	0	°C
F03	Inlet water temperature correction	-5-5	0	minute
F04	Start delay	1-5	3	minute
F05	Menu password	0~9999	8888	/
F06	Defrosting time	1-45	3	minute
F07	Defrosting cycle	10-240	60	minute
F08	Fahrenheit and Celsius display switching	0~1	0	/
F09	Upper temperature limit	2-43	40	°C
F10	Lower temperature limit	1-43	2	°C
F11	Compressor current overload protection	0-25	12	A
F12	Overload delay protection	2-29	10	Second
F13	Display temperature switch	0:In 1:Out	0	/
F14	Ozone running time	0-180	60	minute
F15	Fan overload protection	0-10	5	A
F16	Water pump overload protection	0-6	5	A
F1-01	Water pump impeller (stuck)	0-220	200	HZ
F1-02	Water pump impeller rotation frequency (lack water)	220-320	300	HZ
F1-03	Water pump impeller rotation frequency (no water)	320-340	320	HZ
F18	Chiller pressure detection	0:ON 1:OFF	0	
F19	Temperature difference	0-45	5	°C
F20	Detection function	0:ON 1:OFF	1	/
F21	Standby display	0-200	15	minute



Parameter annotation

F01	When the water temperature is equal to or higher than the target temperature, start cooling; when the water temperature is equal to or less than the target temperature , start heating
F02	When the displayed temperature deviates from the actual temperature, this function can be used for calibration.
F03	When there is a deviation between the inlet water temperature and the displayed water temperature, you can use this function to correct it. When you click on the correction, a pop-up prompt will appear to confirm the current temperature and then enter the correction numeric keyboard pop-up window.
F04	After clicking on, there will be a 3-minute countdown. If the water pump does not report an error, the compressor and fan will be started.
F05	Click setting and you will be prompted to enter the password to enter the settings.
F06	Defrost operation, and it will exit defrost when the time is over
F07	Defrost will be executed when the continuous operation time of electric heating reaches the factory setting
F08	Set to 0: Celsius mode set to 1: Fahrenheit mode
F09	Limit the maximum value of the target temperature, when the temperature exceeds this set value, the over-temperature protection will be triggered.
F10	Limit the lowest value of the target temperature, when the temperature is lower than this setting, the ultra-low temperature protection will be triggered.
F11	The current exceeds this setting value and will triggers overload protection when the compressor is working .
F12	If the compressor of working current overload duration is greater than this setting value, then will trigger this protection.
F13	Set to 0: to display the internal temperature of the evaporator; to 1: to display the water inlet temperature
F14	After press the "Ozone" button , it will start counting down according to this setting time. When the countdown ends, it will stop the "Ozone" to continue working.
F15	The current of the fan exceeds this setting value when the fan is working then will triggers the overload protection
F16	The current is lower than this setting value when the water pump is working and then will triggers the overload protection.The monitoring starts after 5 minutes of power on.
F1-01	The water pump is stuck and there is no water flow
F1-02	The water pump is running normally and the water flow is small
F1-03	The water pump is running normally but no water flow in the waterway
F18	Detect the refrigerant pressure of the chiller system through a pressure switch
F19	The absolute value of the subtraction between the monitored inlet water temperature and the monitored evaporator internal temperature
F20	Set to 0: All detection function device will invalid. Set to 1: All detection function device will be valid
F21	Automatic screen save time

6. Technical Specification

Chiller parameters

POWER	AC110V/60Hz	<h3>Characteristics</h3> <ol style="list-style-type: none"> 1. Powerful enough (1HP) 2. Water and electricity separation system, UL approved Leakage protection plug 3. Overheat protection. Overload current protection 4. Move the lightning protection function of the power supply system 5. Automatically self-check system. Compressor, fan, waterpump abnormal 6. Indoor or outdoor using 7. Easy set up and connection, hose set with quickwaterproof connectors included 8. Housecover with outdoor metal paint baking process, durable. 9. Built-in ozone disinfection device and water filter 10. Power loss memory function. 11. Automatic constant temperature system. 12. High-precision sensing system.
RATED COOL/HEAT CAPACITY	2700W	
RATED COOL/HEAT POWER	1050/1150W	
RATED COOL/HEAT CURRENT	9.5/10.5A	
MAXCOOLING POWER	1188W	
MAX CURRENT	10.8A	
S.S./D.SPRESSURE	<1.6/4.2MPa	
PUMP RATED POWER	88 W	
PUMP RATED CURRENT	4.2 A	
PUMP MAX FLOW	30L/min	
REFRIGERANT/CHARGE	R410a/640g	
ELECTRIC SHOCKPROOF	TYPEI	
WATERPROOF	IPX4	
DIMENSION	27-1/2"x17-3/4"x19-1/2"	
N.W	49KGS	
G.W	53KGS	

FAQ:

- ① **Why has condensate water come out from the chiller?**
This is caused by temperature difference between the inside and outside of the chiller pipe system.
- ② **Why has smoke coming out from the chiller?**
When chiller is defrosting under the heater mode, it may generate smoke-like vapors. This is normal.
- ③ **The chiller has its own filter, so why is the water still turbid?**
The filter mainly filters hair, dandruff, etc. from entering the chiller system to ensure the normal operation of the chiller. If you want to achieve the purpose of purifying water, you can add flocculant and water purifier for clarification treatment.
- ④ **How to perform maintenance during extreme weather? How to prevent pipelines from freezing and breaking?**
It will need to blow out all the water in the pipes, and fill them with water again when starting up later. Because if has water inside the pipes, it will freezing and crack.

Filter Maintenance Suggestion

- ① Please clean the filter cartridge weekly or when it looks dirty
- ② Please replace the filter cartridge every 1-6 months based on usage.
- ③ Please replace the filter cartridge when the water flow is still slow after cleaning the filter cartridge.



1. Use a wrench to unscrew the filter container and remove the old filter cartridge



2. Unpack the new filter cartridge and place it to the bottom of the filter container



3. Close the filter container and fasten with a wrench



4. Check for water leakage before the replacement is complete

Useful Tips

1. It is normal to have condensations on the hoses, chiller housing cover, or around the tub. The condensations happen when these tub/chiller parts are colder than the air around.
2. The fan in the chiller starts running 3 minutes after the machine operation is normal.
3. A noise level of around 55 decibels is normal.
4. When the temperature reaches the target value, the cooling compressor will stop. The water circulation pump continues to run is normal.
5. A one-to-two-degree temperature differences between the control panel display and the actual tub water is normal.
6. This tub equips with an ozone sanitizer. Please let it run for 30-60 minutes after taking a bath. It helps to prevent Biofilm under moderate use. However, please change the water frequently or use a spa water maintenance device for best result. (Please refer to the "Water Maintenance" section.)
7. Due to the natural characteristics of solid wood, if it is not used for a long time or due to temperature changes, the wood may expand and contract due to heat and cold. This may cause small leaks at the bottom of the tub, if such leak happens, please use the repair kit to re-seal the tub according to the repair methods in the manual.
8. When using the heater function, you may see smoke-like vapors coming out of the chiller. This is part of the defrosting process and is normal.
9. A set of repair kit is included for touch up and repair. If the repair and patch job don't fix the leakage, please email help@woodbridgebath.com for further assistance.
10. Extra water filter cartridges are included. Please replace the cartridge whenever the water flow is still weak after cleaning the cartridge. Email help@woodbridgebath.com to order more replacement filter cartridges if needed.

IMPORTANT!

DO NOT USE: Abrasive cleaners such as: acid, ammonia, bleach, and similar solutions. Use of such solutions may cause corrosion, finish peeling, and/or dull the surface.

DO NOT USE: Abrasive sponges or cloth. Never use steel, wool, or wired brushes that will permanently scratch

Retain these installation instructions for future reference!

Thank you for using WOODBRIDGE products!

WOODBRIDGE®

California (Norwalk) Distribution Center
15600 Blackburn Ave, Norwalk, CA 90650

New Jersey (Somerset) Distribution Center
635 Pierce St, Somerset, NJ 08873

Florida (Orlando) Distribution Center
13645 S Orange Ave, Orlando, FL 32824

Canada (Ontario) Distribution Center
615 Orwell Street, Unit B, Mississauga, ON L5A2W4, Canada

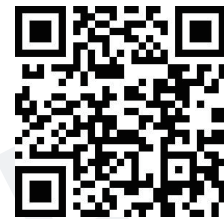

Please don't hesitate to contact us if you have any questions or concerns.

Customer Service Phone: 562-229-0088. (Monday - Friday 9 AM - 5 PM Pacific Time)

Or Email: help@woodbridgebath.com

