

Installation Instruction

Wooden Bathtub

WOODBIDGE®

Model: WB4301



READ ALL INSTRUCTIONS BEFORE UNPACKING THE PRODUCT

INSTRUCTIONS THAT, IF IGNORED, COULD RESULT IN DEATH OR SERIOUS INJURY CAUSED BY INCORRECT HANDLING OR INSTALLATION OF THE PRODUCT. THESE INSTRUCTIONS MUST BE OBSERVED FOR SAFE INSTALLATION.

CAUTION!



**TWO PEOPLE
LIFT REQUIRED**

**2 PEOPLE ARE REQUIRED TO LIFT AND DURING
ENTIRE INSTALLATION OF THIS PRODUCT**

This product must be installed by a fully insured and licensed bathtub installer.

We are not responsible for local code compliance for this product. Building and plumbing codes may vary from state-to-state in accordance to your location. We are not responsible for providing any compliance certifications.

Under no circumstances we are liable for any and all incidental damages sustained in connection with this product. Neither manufacturer, distributor or retailer is responsible for water damage or flood caused by the usage of this product.

Under no circumstances we are liable for any and all fees, cost of installation/reinstallation/removal, subsequent damages or transportation in case of the product defect.

1. Safety Regulations

- ① Children can use it but must be under adult supervision.
- ② It is contraindicated to those who experience skin erosion or any unhealed wounds due to surgery.
- ③ Use with caution after drinking alcohol.
- ④ Consult with your doctor before use when you're feeling sick, taking medication, or pregnant.
- ⑤ Water temperatures above 100°F may cause hyperthermia and/or other health problems. Check the water temperature and adjust it to your comfort.
- ⑥ Don't overfill the tub before getting in the water. Overfilling can lead to spills and slippery conditions when entering the tub. Be extremely careful when entering and exiting.

2. Product information

Product Name: Wooden Bathtub

Model: WB4301

Size: 43 1/4"(L) x 25-5/8"(W) x 32-5/8"(H)

Water Volume: 460L / 122GAL

Capacity: 1 person

Material: Thermo rubber wood

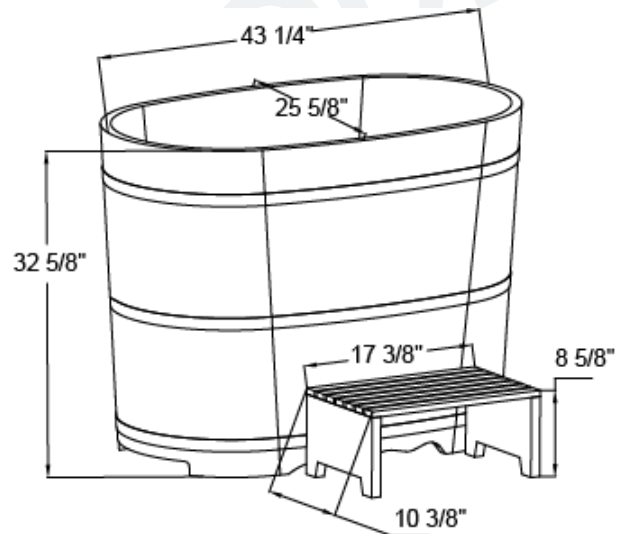
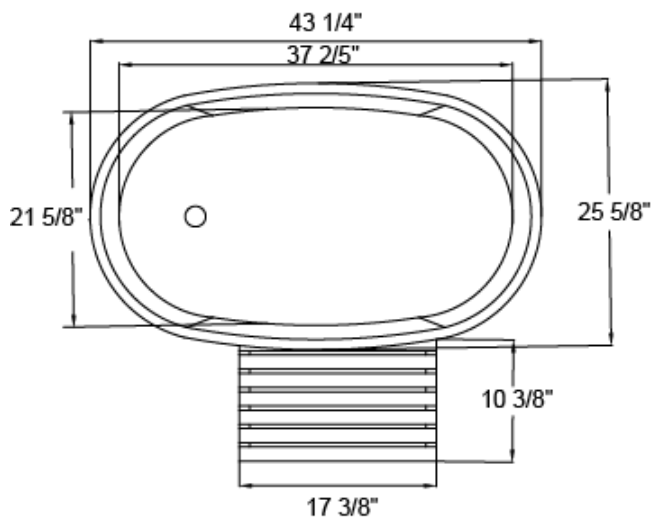

*Since the wooden barrel is purely handmade, the product size will be with a reasonable tolerance. Please refer to the actual size.

Accessories :



● Stepping Stool*1



● Seat*1



● Tub Drain Stopper*1



● Wooden Tub Repair Kit*1



Outer dimensions	43 1/4" x 25-5/8" x 32-5/8"
Volume	460L / 122GAL
Capacity person	1
Material	Thermo rubber wood
Drain	Included
Inlet and Outlet	Included

FAQ:

Why do wooden tub leak after not being used for a period of time?

Due to the natural characteristics of solid wood, if it is not used for a long time or due to temperature changes, it will cause the wood to expand and contract due to heat and cold, resulting in small leaks at the bottom. When encountering this situation, please use the repair kit to repair according to the repair methods in the manual.

4. Wooden Tub Maintenance:

- ① Clean the tub with a soft brush or sponge, and rinse it with clean water after removing the dirt. Do not use sharp objects or hard brush to scrape the wooden tub. It will damage the waterproof capability of the wooden tub.
- ② Depending on environmental factors and usage levels, please repaint the wooden tub every 1-2 years if needed.
- ③ Due to the natural characteristics of solid wood, if it is not used for a long time or due to temperature changes, the wood may expand and contract due to heat and cold. This may cause small leaks at the bottom of the tub. If such leak happens, please use the repair kit to re-seal the tub according to the repair methods in the manual.
- ④ To prevent hoses from rupturing in temperatures below the freezing point (32 °F or 0 °C), it is necessary to drain all water from the hoses. When restarting later, the pipes can be refilled with water. This practice helps avoiding damages caused by the expansion of freezing water, which can lead to pipe rupture.



How to use the tub repairing kit

- ① Locate the water-leaking area and use a clean towel or paper towel to wipe out the water and clean up the leaking surface area.
- ② Place the mixing nozzle on the tip of the glue container and insert the glue injector from the other side of the glue container.
- ③ Gently press on the glue injector to apply a bead of glue around the leaking surface. Use the spreader immediately to spread the glue evenly."
- ④ Use the touch-up brush to fine-patch any uneven surface area and remove any excess glue.
- ⑤ Let the glued area dry for a minimum of 24 hours till it is fully dry.
- ⑥ Check for any leaking before use.
- ⑦ Following these steps should help you fix leaks in your tub effectively. Remember to allow sufficient time for the glued area to dry before using the tub again. If the issue persists after following these steps, it is advisable to reach out to WOODBRIDGE Customer Service for additional assistance.

Woodbridge warrants its products as listed in below to be free of material and workmanship defect, subjected to the limitations set forth in this limited warranty.

- **Bathtub, Whirlpool/Air Bubble Massage Tub, Wooden Cold Plunge: 1 Year limited to be free of defects in material and workmanship.**
- **Toilet and Bidet: 1 Year limited to be free of defects in material and workmanship.**
- **Faucet: 1 Year limited to be free of defects in material and workmanship.**
- **Vanity: 1 Year limited to be free of defects in material and workmanship.**
- **Granite, Marble, Engineered Quartz Vanity Top: 1 Year limited to be free of defects in material and workmanship.**
- **Medicine Cabinet, LED Mirror: 1 Year limited to be free of defects in material and workmanship.**
- **Stainless Steel Sink: 1 Year limited to be free of defects in material and workmanship.**
- **Solid Surface Shower Wall Panel, Shower Base and Vanity Top: 10 Years limited warranty to be free from material defects.**
- **Shower Door: Lifetime warranty on glass components and 1Year limited on other hardware.**

This limited warranty is non-transferable and only applies to products purchased and installed in the United States and Canada.

This limited warranty excludes all industrial, commercial and business usage. Proof of purchase (original sales receipt) from the original purchaser, Description and pictures of defect, model number or model description must be provided to Woodbridge Bath for all warranty claims and Woodbridge Bath IS NOT responsible for labor cost, removal or installation costs.

This limited warranty shall not apply to goods which have been subject to accident, negligence, improper installation, product abuse, product misuse, or use of cleaners containing abrasives, alcohol or other organic solvents, whether performed by a contractor, service company, or yourself, are excluded from this warranty.

This warranty does not cover surface damaged caused by use of chemicals that break through or dissolve the surface finish or damage caused by the accidental dropping of sharp or heavy objects. Improper care and use of abrasive cleaners and will void the warranty.

During this limited warranty period if a malfunction occurs and after inspection it is determined that a defect developed during normal use, Woodbridge will as at its election proceed with any of the following options:

- (1) repair or replace the defective part(s) or product(s) at cost
- (2) issue a refund of the original purchase price of the product(s) (Valid within 30 days from the date of purchase)
- (3) issue a credit to be applied toward the purchase of a new product. Shipping/delivery charges may apply and are in sole discretion.

Caution:

NEVER use cleaners containing abrasive cleaners, ammonia, bleach, acids, waxes, alcohol, solvents or other products that are not recommended for Chrome finish will void the warranty.

Woodbridge products should be installed by a fully insured and licensed contractor only. Installation by anyone other than fully insured and licensed contractor will void this limited warranty.

RESPONSIBILITIES OF OTHERS

Inspecting the unit prior to installation is the responsibility of the installer or building contractor who acts on behalf of the user. They are responsible for ensuring the unit is free of defect or damage. Notices are placed on the unit and on the shipping carton advising the installer of this responsibility. In the event of a problem, the unit must not be installed. Woodbridge is not responsible for failures or damage that could have been discovered, repaired, or avoided by proper inspection and testing prior to installation.

Damage occurring in transit is the responsibility of the carrier. The user or installer MUST open the crate and inspect the unit for damage when it is delivered. If damage is discovered, it must be reported immediately to the seller and the carrier in writing, and an inspection requested. Failure of the carrier to respond should be reported to the seller and the carrier. Your freight claims should be filed promptly thereafter.

This limited warranty does not cover any liability for consequential or incidental damages, all of which are hereby expressly disclaimed, or the extension beyond the duration of this limited warranty of any implied limited warranties, including those of merchant ability or fitness for an intended purpose.

DISCLAIMER

Except as expressly provided, there shall be no warranty or obligation, express or implied, oral or statutory. No dealer or other person has the authority to make any warranties or representations concerning or its products. In no event shall be held responsible for any such warranties or representations.

Some states/provinces do not allow limitations on how long an implied warranty lasts, or the exclusion on limitation of special, incidental or consequential damages, so these limitations and exclusions may not apply to you. This warranty gives you specific legal rights, you may also have other rights which vary from state/province to state/province.

To obtain warranty and replacement parts, please send e-mail to help@woodbridgebath.com with the original receipt information, Woodbridge will determine whether to repair or replace your product, issue a refund or issue a credit.

IMPORTANT!

DO NOT USE: Abrasive cleaners such as: acid, ammonia, bleach, and similar solutions. Use of such solutions may cause corrosion, finish peeling, and/or dull the surface.

DO NOT USE: Abrasive sponges or cloth. Never use steel, wool, or wired brushes that will permanently scratch the

Retain these installation instructions for future reference!

Thank you for using WOODBRIDGE products!

WOODBRIDGE[®]

California (Norwalk) Distribution Center
15600 Blackburn Ave, Norwalk, CA 90650

New Jersey (Somerset) Distribution Center
635 Pierce St, Somerset, NJ 08873

Florida (Orlando) Distribution Center
13645 S Orange Ave, Orlando, FL 32824

Canada (Ontario) Distribution Center
615 Orwell Street, Unit B, Mississauga, ON L5A2W4, Canada



Please don't hesitate to contact us if you have any questions or concerns.

Customer Service Phone: 562-229-0088. (Monday - Friday 9 AM - 5 PM Pacific Time)

Or Email: help@woodbridgebath.com

BRIDGE® WOODBRID
BRIDGE® WOODBRID
BRIDGE® WOODBRID